

MAX. TIGHTENING TORQUE FOR TERMINAL BLOCKS 1492-HM1: 7 LB-IN.
 MAX. TIGHTENING TORQUE FOR TERMINAL BLOCKS 1492-CA1: 16 LB-IN.

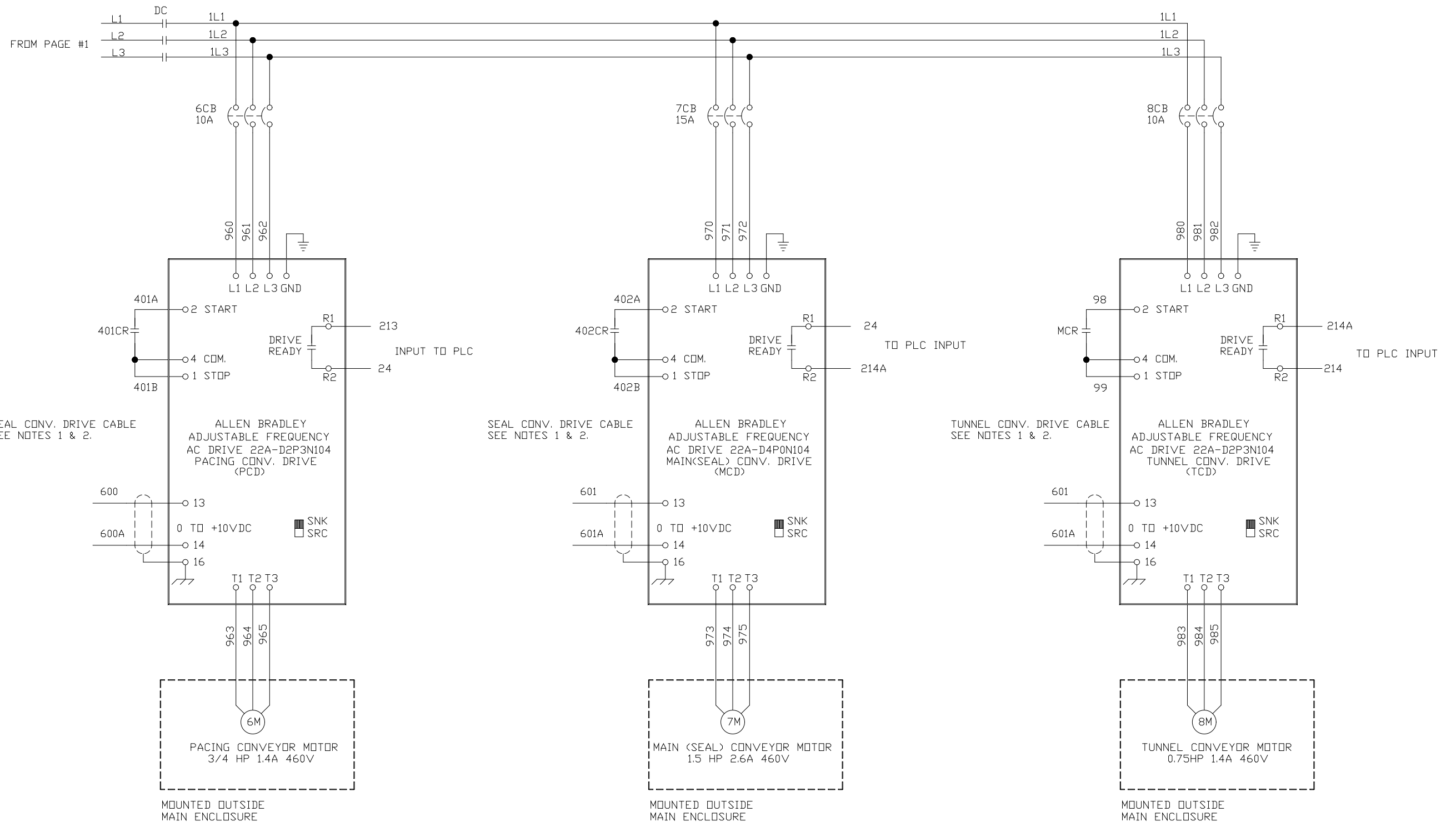

PROVIDE TERMINATED WIRES FOR OPTIONAL EQUIPMENT

		CORPORATION	
		9511 W.RIVER ST. SCHILLER PARK, ILLINOIS 60176	
SCALE: NONE	REVISION:	DRAWN BY: HS	
SHEET: 1 of 6	4540B01	REVISED: 07-09-2004	
MODEL:	45TW-28SB ELECTRICAL SCHEMATIC		
GERBER PRODUCTS		DRAWING NUMBER: 5740-99-01	



**POWER FLEX 4 DRIVE SET UP
(DIFFERENT THAN DEFAULT)**

DISPLAY	PARAMETER DESCRIPTIONS	SETTING
P031	RATED VOLTAGE	460
P033	MOTOR OL CURRENT	2.6 *
P036	START SOURCE	2
P038	SPEED REFERENCE	2
P039	ACCELERATION TIME	2
P040	DECELERATION TIME	2
A092	AUTO RESTART TRIES	4
A094	START AT POWER UP	1

* SET TO THE MAXIMUM ALLOWABLE MOTOR CURRENT

NOTES:

1. USE BELDON #8761 OR EQUIVALENT 18GA WIRE
2. CONNECT SHIELD ONLY AT DRIVE END (TERMINAL GND) STUB AND INSULATE OTHER END.

		CORPORATION	
		9511 W. RIVER ST. SCHILLER PARK, ILLINOIS 60176	
SCALE: NONE	REVISION:	DRAWN BY: HS	
SHEET: 2 of 6	4540A02	REVISED: 07-09-2004	
MODEL: 45TW-28SB		ELECTRICAL SCHEMATIC	
GERBER PRODUCTS		DRAWING NUMBER: 5740-99-02	

24

INPUT MODULE #1

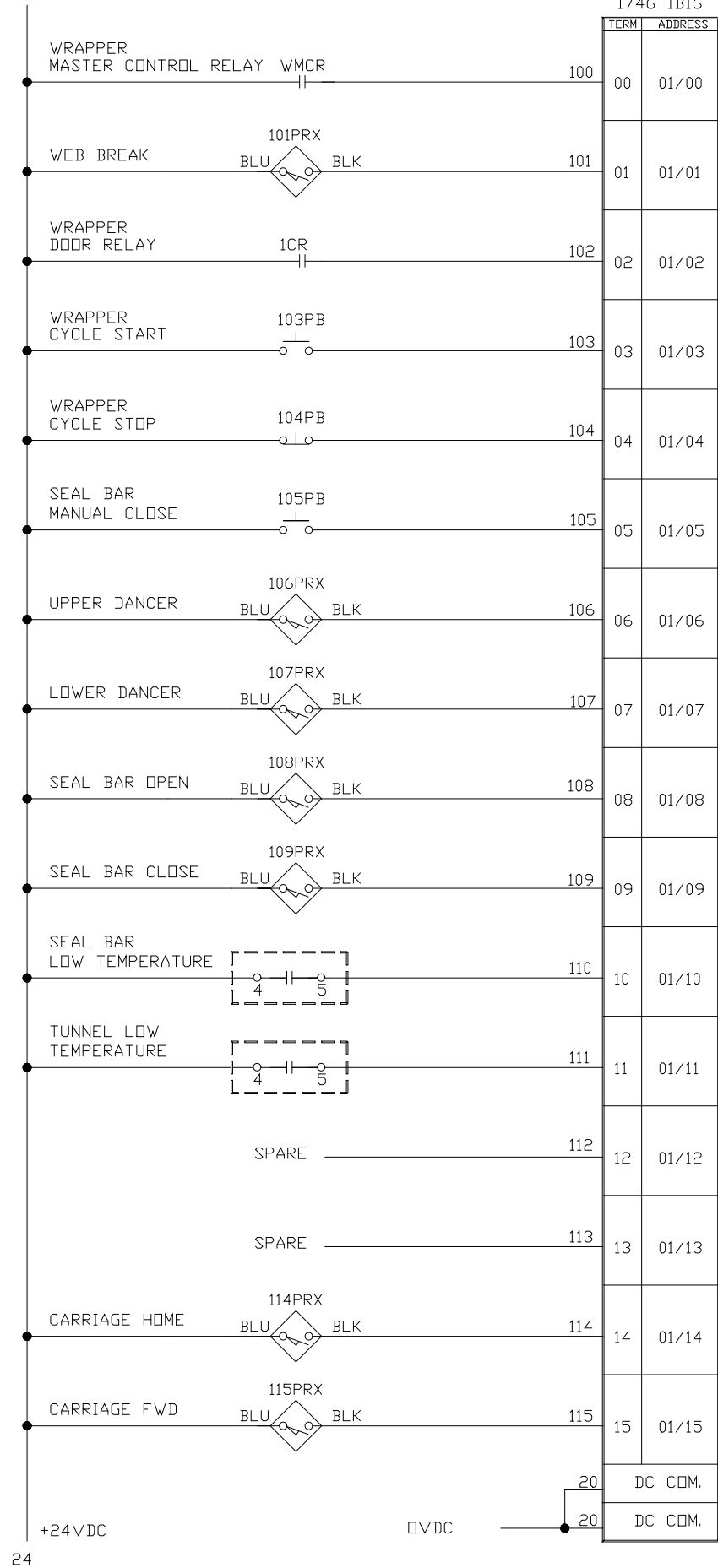

24

24

INPUT MODULE #2

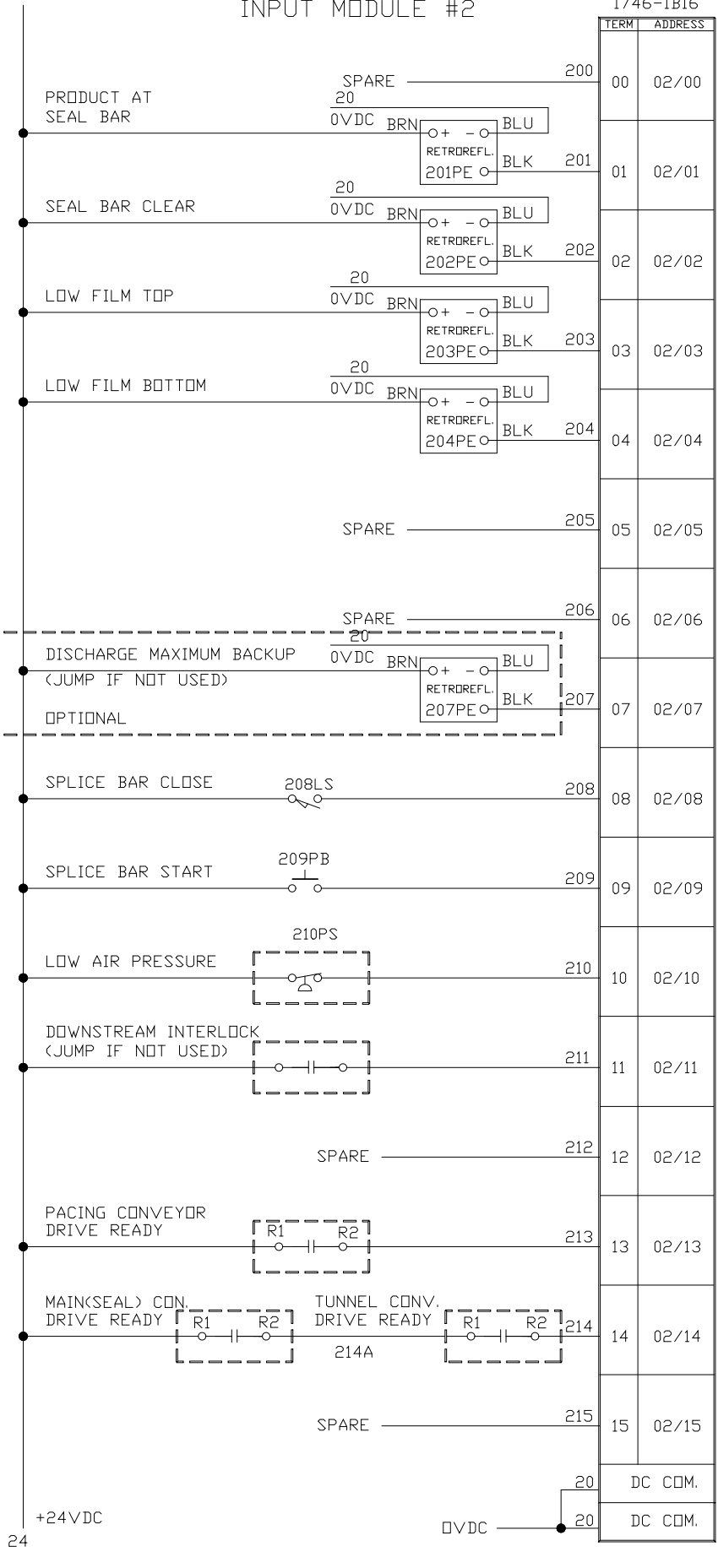

24

		CORPORATION	
		9511 W. RIVER ST. SCHILLER PARK, ILLINOIS 60176	
SCALE: NONE	REVISION:	DRAWN BY: HS	
SHEET: 3 of 6	4500A03	REVISED: 07-09-2004	
MODEL 45TW-28SB		ELECTRICAL SCHEMATIC	
GERBER PRODUCTS		DRAWING NUMBER 5740-99-03	

OUTPUT MODULE #3

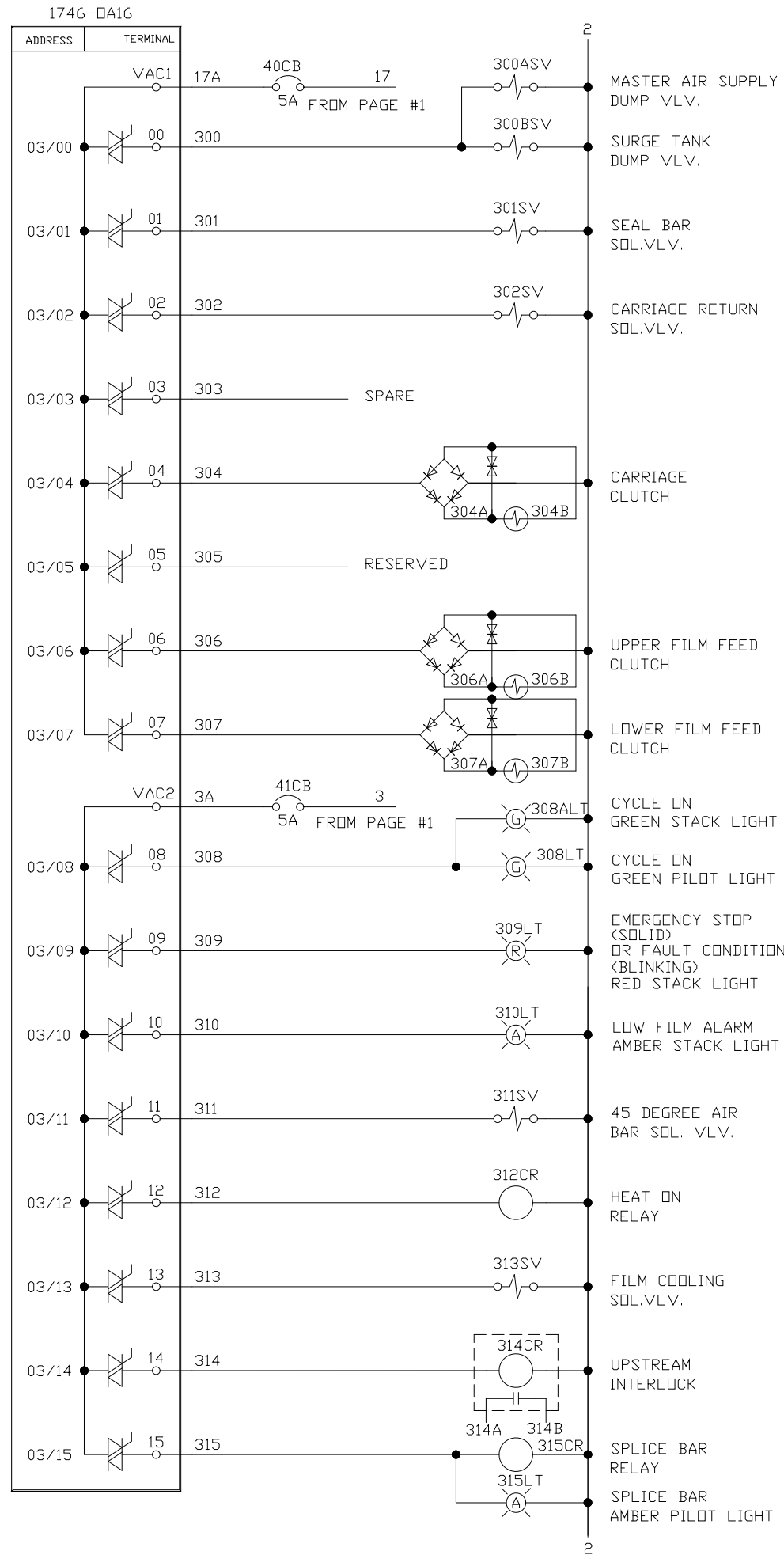

OUTPUT MODULE #4

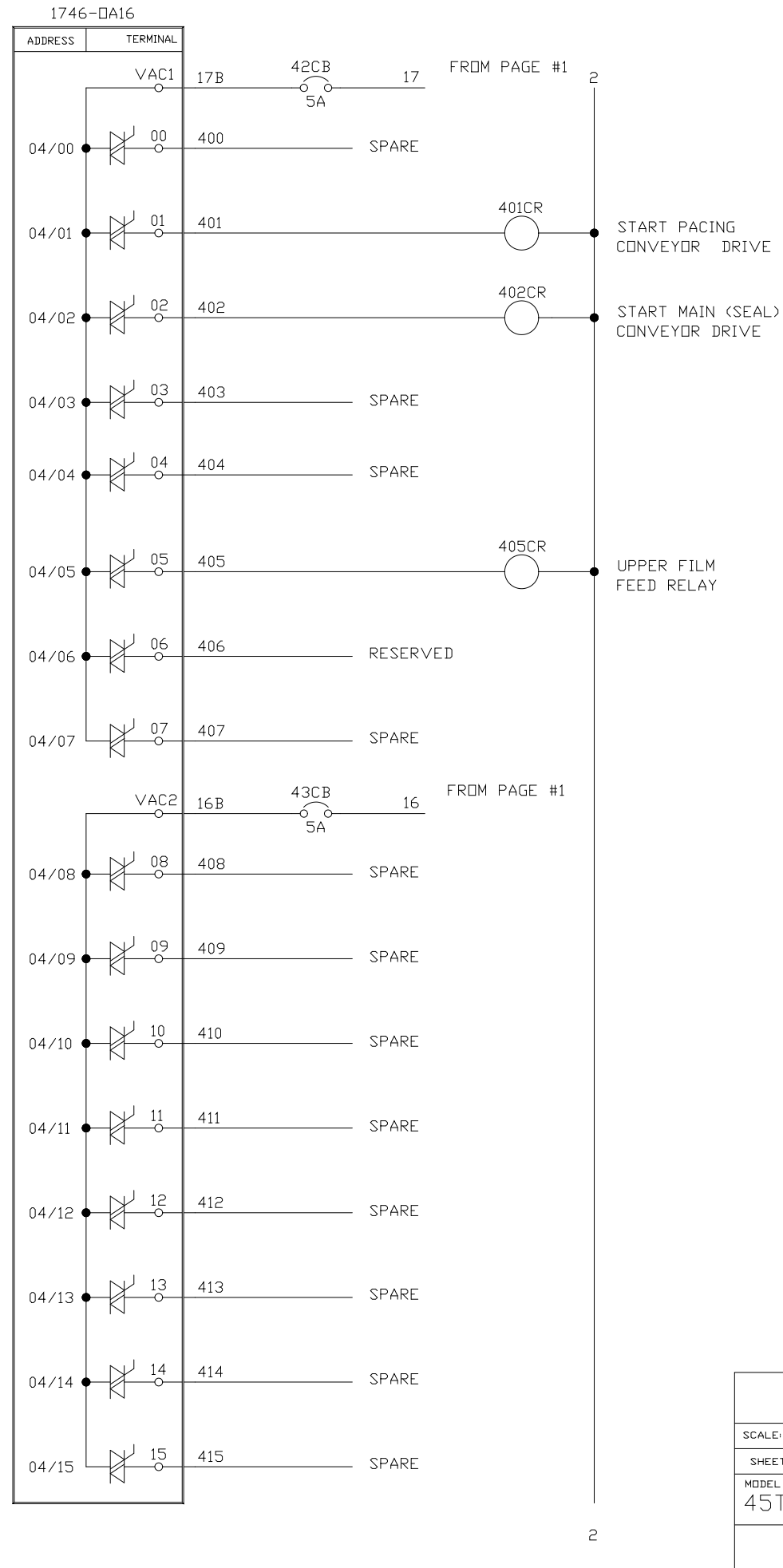

		CORPORATION	
		9511 W RIVER ST. SCHILLER PARK, ILLINOIS 60176	
SCALE: NONE	REVISION:	DRAWN BY: HS	
SHEET: 4 of 6	4500A04	REVISED: 07-09-2004	
MODEL 45TW-28SB		ELECTRICAL SCHEMATIC	
GERBER PRODUCTS		DRAWING NUMBER 5740-99-04	

OUTPUT MODULE #6

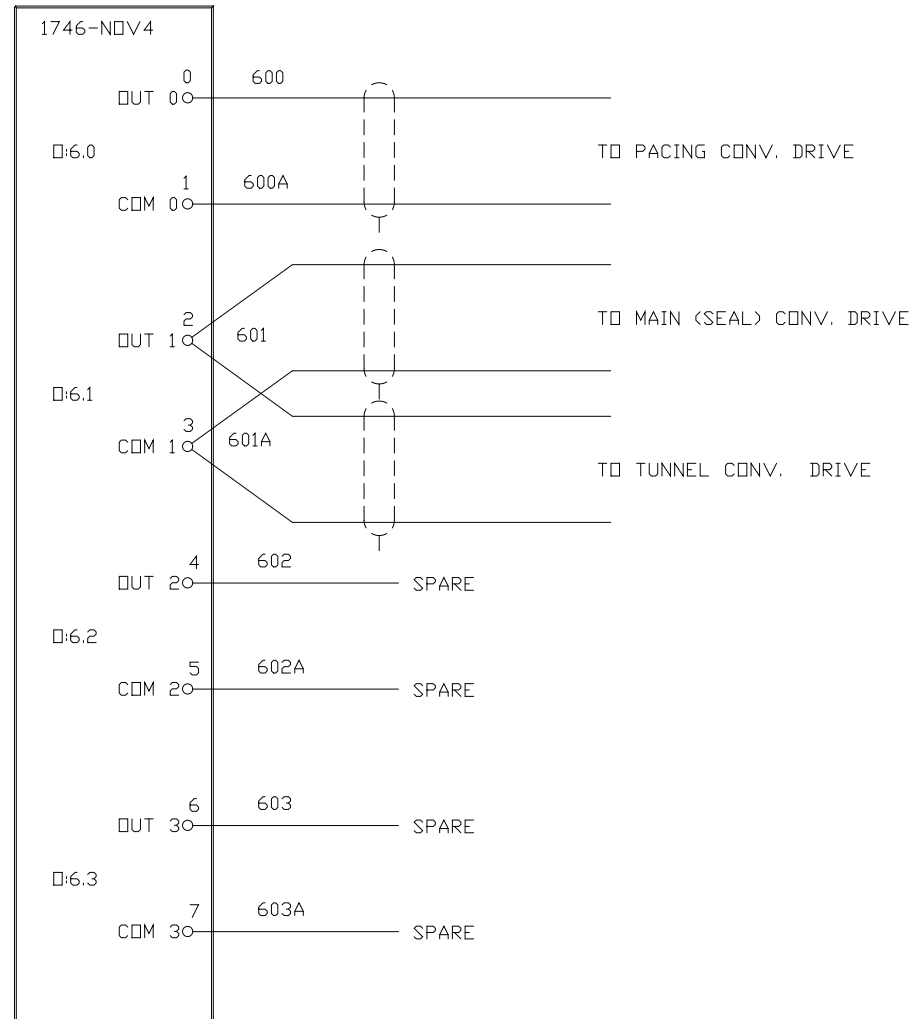

EXTERNAL

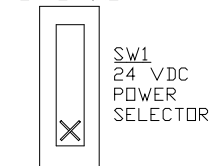

BACKPLANE

X = SWITCH POSITION

NOTES:

1. USE BELDON #8761 OR EQUIVALENT 18GA WIRE
2. CONNECT SHIELD ONLY AT DRIVE END (TERMINAL GND) STUB AND INSULATE OTHER END.

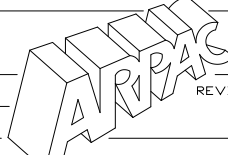
 CORPORATION 9511 W RIVER ST. SCHILLER PARK, ILLINOIS 60176		SCALE: NONE	REVISION:	DRAWN BY: HS
		SHEET: 5 of 6	4500A05	REVISED: 07-09-2004
45TW-28SB		ELECTRICAL SCHEMATIC		
GERBER PRODUCTS		DRAWING NUMBER 5740-99-05		

ALLEN BRADLEY SLC-5/03 (7 SLOT RACK 1746-A7)

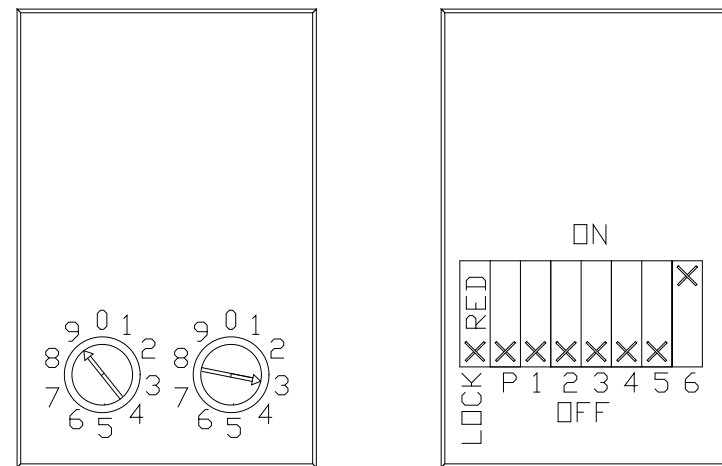
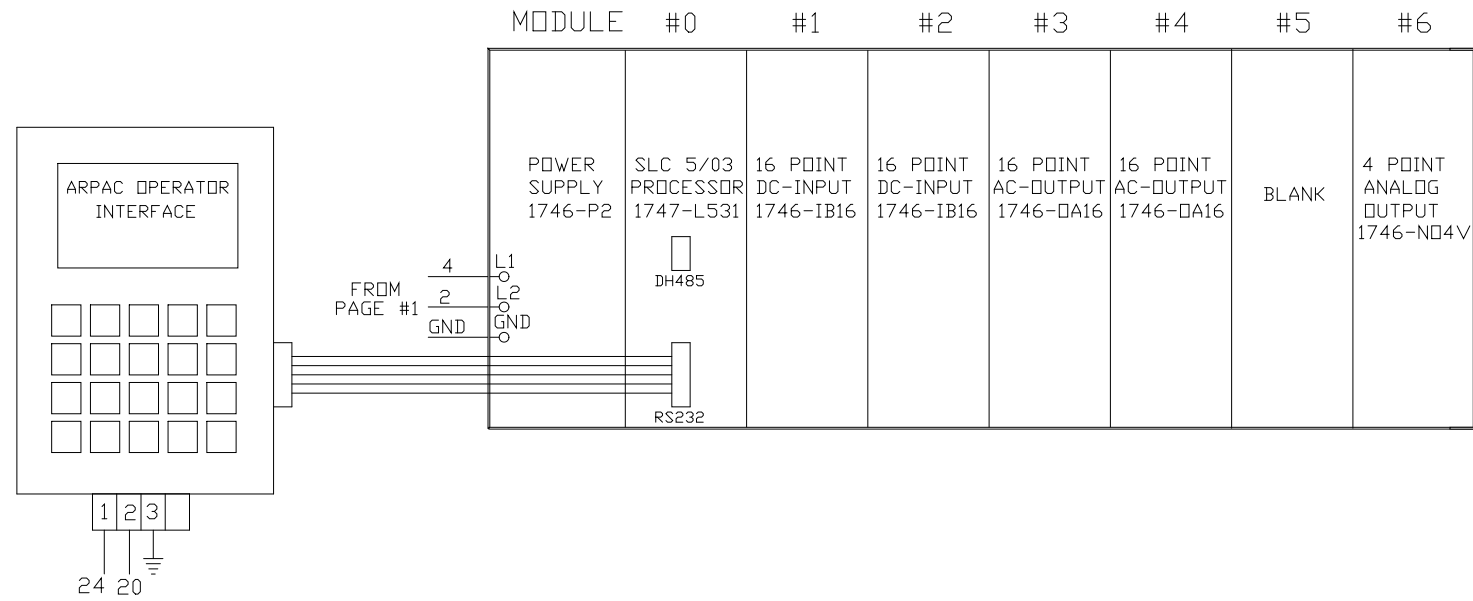

OMRON E5CS-R1KJX
ROTARY AND DIP SWITCH SETTINGS

DEFAULTS

500 DEG. F. MAX (FOR 999 DEGREE MAX SET LEFT DIP SW TO #6)
J TYPE THERMOCOUPLE PID CONTROL
(FOR 999 DEGREE MAX SET LEFT ROTARY SW TO #6)

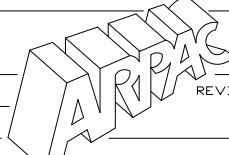
 ARPAC CORPORATION 9511 W RIVER ST. SCHILLER PARK, ILLINOIS 60176		SCALE: NONE	REVISION:	DRAWN BY: HS
		SHEET: 6 of 6	4500A06	REVISED: 07-09-2004
MODEL 45TW-28SB		ELECTRICAL SCHEMATIC		
GERBER PRODUCTS		DRAWING NUMBER 5740-99-06		