



ARPACSTRETCH™ ORBITAL® SERIES

HORIZONTAL FULL ENCLOSURE STRETCH WRAPPING SYSTEM

The ARPAC ORBITAL SERIES stretch wrap system is the next generation of horizontal stretch wrap machinery. The traditional ARPAC rugged design and high end components are only the start. The ORBITAL SERIES leaves the competition in the dust with built in features such as and Allen-Bradley® Micrologix PLC, Panelview 600 color touch screen operator interface, all UL approved components and more, plus the ORBITAL SERIES is the only machine of its kind that can be fitted with a powered film pre-stretch system for optimal film usage.

- Unitizes loose bundles together such as piping, sheets and other long product
- Primary packaging - protecting product from dirt, dust and abrasions
- Suspension packaging - locking unstable product to stable platform
- Compression wrapping - using wrapping force to tightly band product together



APPLICATIONS

- Doors
- Windows
- Tubes
- Boxes
- Panels
- Furniture
- Blinds
- Shelves
- Artwork
- Moldings
- Aluminum Profiles
- Plastic Sheet
- Cartons
- Automotive Parts
- Pallet loads



EZ-LOAD FLM-SAVR® Film Carriage with "Swift Change" Film Mandrel



Optional Adjusting Guides



User-Friendly Operator Controls

FEATURES

- Welded heavy-duty reinforced structural steel construction for around-the-clock operation
- Powder coat finish that provides a durable scratch resistant surface and prevents corrosion
- 1HP DC main drive w/electric brake for accurate stopping
- Allen-Bradley® Micrologix PLC
- User-friendly operator controls
- Built in self-diagnostics
- Electronically controlled film tension adjustment
- Cycle pause and ring jog control
- Positive home position alignment
- Photo electric load sensor
- Corner compensation
- Anti-static pre-stretch rollers
- UL approved components
- External fuses
- No film or film break audible alarm
- Variable speed
- Film delivery: 1/2 HP, 90 VDC motor
- 200% pre-stretch

OPTIONS

- Custom infeed and exit conveyors
- Automatic side guides
- Powered bridge conveyor
- Pneumatic hold down - for holding product in place
- Powered bridge conveyor product transfer
- EZ-LOAD FLM-SAVR® Powered Pre-Stretch 150%-300% (200% standard)
- NEMA 12 enclosure
- Additional ring sizes available through application engineering
- More options available, consult your local ARPAC representative

For complete product line, visit: www.arpac.com

SPECIFICATIONS

Power Requirements

- Electrical: 230V, 3Ph, 60Hz
Other voltages available

Load Sizes

| Ring Size | Max RPM | Max Load Diagonal | Ship Weight |
|-----------|---------|-------------------|-------------|
| 36" | 50 | 30" | 1500 lb |
| 48" | 40 | 42" | 2000 lb |
| 60" | 30 | 54" | 2500 lb |

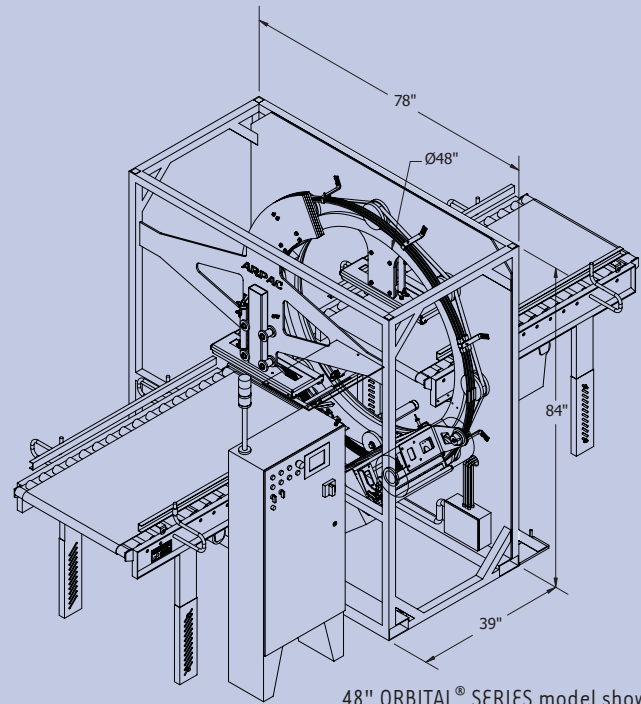

48" ORBITAL® SERIES model shown

