

# BVM



BRUNNER GMBH u. Co. KG  
Packaging machines



*Compacta -  
perfection in packaging*



**Compacta Series**  
of Overwrapping Machines

# BVM Assembly

BVM Brunner GmbH u. Co. KG is a privately-owned medium-sized company that started designing and building packaging machines in 1985. Today the company supplies high quality, innovative machines to the global packaging industry, and BVM Brunner's network of sales partners provides advice and support to companies worldwide.

2 BVM likes to take advantage of opportunities arising from advances in engineering and manufacturing; the use of precision aluminium profiles, laser technology, state-of-the-art electronics, and a modular machine design is **engineering** at its best. A BVM machine keeps you ahead of the competition.



*BVM - Final Assembly  
and Start-Up*



**BVM**





*BVM - Compacta  
Assembly*



3



**BVM**  
BVM BRUNNER GMBH  
Verpackungsmaschinen  
Ferdinand Lassalle Str.62

**BVM**

# Feeding Systems and Accessories



## **BVM Label Applicator**

for applying pre-printed labels or labels printed by an integral printing unit that is available as an option.

## **BVM Feeder A 3535**

for feeding products directly from a magazine stack onto the feed conveyor of a packaging machine; designed for feeding products – such as journals, catalogues, CDs, DVDs – that can be moved from the bottom of a stack by a shuttle mechanism with suction.





### **BVM Pusher\***

mounted on the infeed conveyor of a Compacta, the pusher is designed for round products such as beaker lids and reels of adhesive tape. The pusher is easily removed; the infeed conveyor can function either as a feed conveyor or as a pusher unit.

\* registered design

5



### **BVM Centrefolder**

available as retrofit unit or integrated in a machine during assembly. Single-wound film can be used with a BVM Centrefolder; the use of single-wound film increases production time by halving the number of reel changes; the Centrefolder unit also simplifies wrapping with preprinted film.

# Compacta 5022, 7522 and 10022

The *Compacta series* of overwrapping machines – designed for fully automatic packaging.

The product flow is inline, also the wrapping cycle is sensor-controlled to facilitate manual or automatic loading. Items are wrapped in centre-folded film that is sealed on the three remaining edges.

Feeding systems ensure *superior performances*; production speeds of *more than 100 packs/minute* are achievable – depending on machine configuration and product.

The *heated, constant-temperature sealing system* can seal all industry standard films, from Polyethylene to Polyolefin to PVC. The BVM side knife produces neat, high-integrity seals, especially when Polyolefin film is used.

Product changeovers do not require the turning of hand wheels or adjustments of product guides, therefore *changeover times are short* and *operational reliability is increased*.

Each Compacta 5022, 7522, 10022 has an upper format limit of app. 18", 27½", 37" respectively. A format limit is the sum of product width plus product height. This way the Compacta series provide professional packaging solutions for a wide variety of applications.



**BVM Touch Screen Control**  
graphical user interface simplifies operating the machine.

Possible Configuration



**Optional Accessories:**  
**BVM Adjustable Draw-Off Rollers\***

increase reliability and minimise film usage.

\*registered design



**Easy Accessible Film Cradle**

makes reel changing operator friendly.

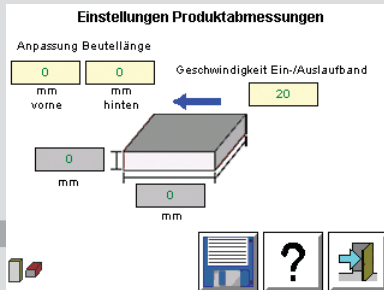

Intuitive user guidance settings. Input of product dimensions at the touch screen.\*

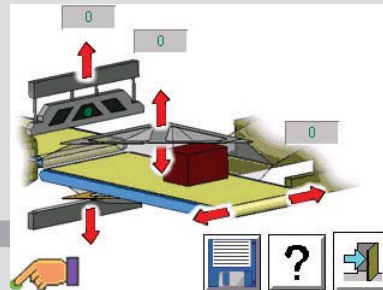

recall of machine settings from job settings memory, push-button changeover.\*

\*depending on fitted options

7



Compacta 5022



# The result: perfection in packaging



8

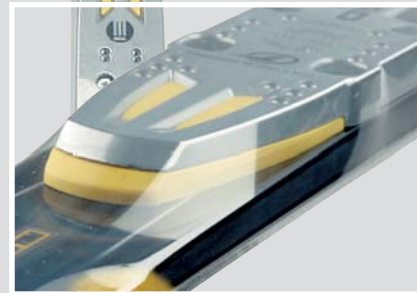
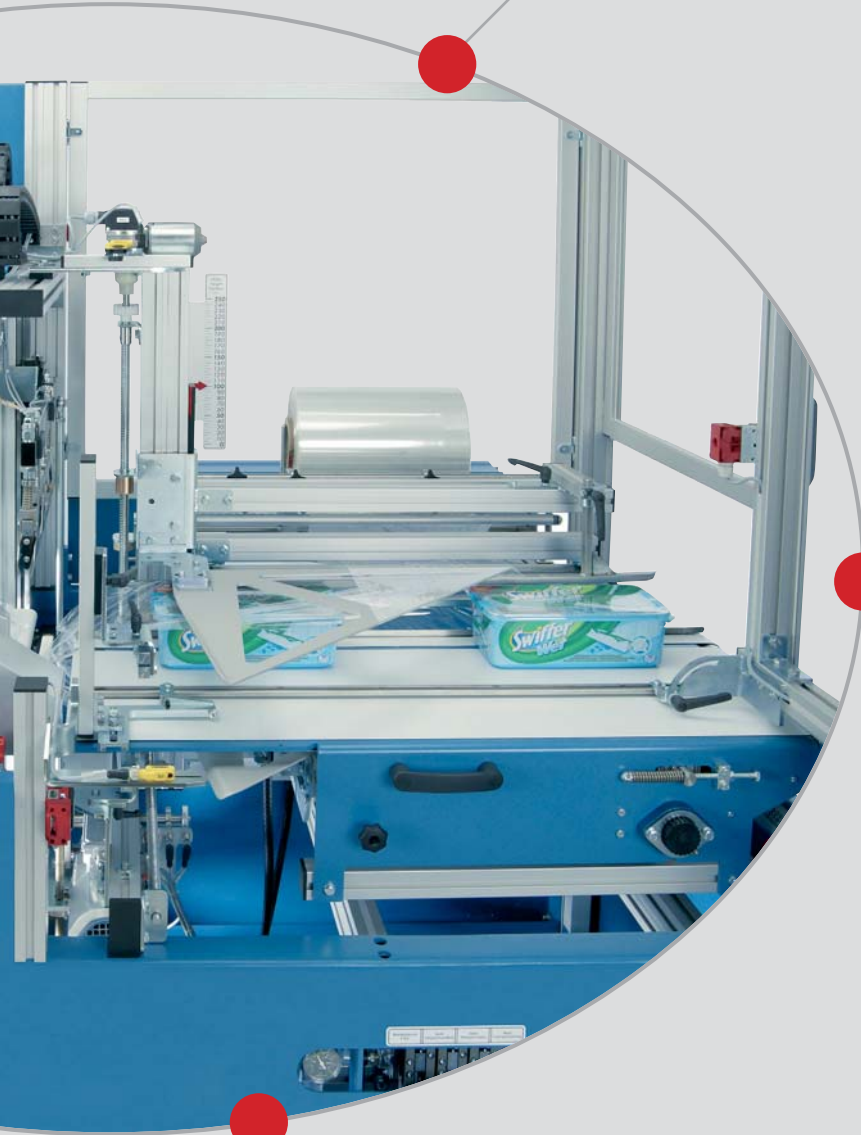

9

# Compacta Konti



**BVM Compacta Konti** is a **continuous-motion machine** that meets the highest demands of production speed and flexibility and is ideal for integration into continuous production processes. The Compacta Konti uses the proven wrapping principle of the Compacta Series: producing fully sealed, high integrity packs by placing products into centre-folded film and then sealing the remaining three edges.

A travelling cross seal bar delivers high performance: up to 130 packs/minute.

Optional accessories provide additional features – such as film folding, print registration – and increase the range of possible applications.

Possible Configuration



Compacta Konti

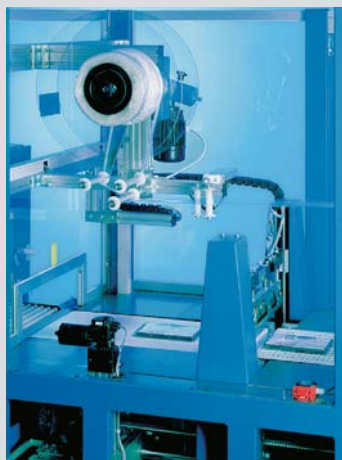

Travelling Cross Seal Bar



Feeder A 3535

# Shrink Tunnel



**BVM** Shrink Tunnels are fitted with rod conveyors; the rods are coated with heat-resistant silicon rubber. A wire-mesh conveyor, a heat-resistant plastic conveyor, and a rod conveyor with life rollers are options. The latter is ideal for use with Polyolefin or PVC films because a complete, even shrink is achieved on the bottom of each pack.

Air flow inside the insulated heat chamber is finely controlled by four dampers – top and bottom on two sides; the dampers are independently adjustable from outside the tunnel.

Possible Configuration



11

Possible Configuration



The conveyor speed is infinitely variable and can be set at the operator station.

The set temperature is maintained accurately by a closed loop, digital temperature controller; the heating can be set at a temperature of up to a maximum of 482 °F.

## Technical Data – Compacta

	Compacta 5022	Compacta 7522	Compacta 10022	Compacta Konti
Upper limit of product width plus product height	(app. 18") 450 mm	(app. 27½") 700 mm	(app. 37") 950 mm	(app. 14") 350 mm
Cross seal bar, width W	(19½") 500 mm	(29½") 750 mm	(39") 1000 mm	(19½") 500 mm
Cross seal bar, clearance H	(8½") 220 mm	(8½") 220 mm	(8½") 220 mm	(6") 150 mm
Increased cross seal clearance, not included as standard	-----	(14") up to 360 mm	(14") up to 360 mm	-----
Film width, centre folded	(25½") 650/650 mm	(33½") 850/850 mm	(45") 1150/1150 mm	(21½") 550/550 mm
Production speed, max	120 packs/min*	60 packs/min*	45 packs/min*	130 packs/min*

Product feeding:	manually or automatically, one of two optical sensors can be selected to establish – either horizontally or vertically – correct product spacing
Size adjustments:	infinitely variable, push-button controlled, motorised (no hand wheels)
Film:	PE-/PVC -/Polyolefin and other sealable, centre-folded films, film thickness 8 – 100 micron*
Film feed:	film cradle with motorised roller, infinitely variable feed, dancer tension control, no mandrel
Trim removal:	wind trim removal system, rewinds up to (4100 ft) 1250 m trim of film with a thickness of up to 15 micron*
Cross seal:	constant-temperature, maintenance-free sealing jaw, jaw clearance and speed infinitely variable
Cross seal drive:	electronically controlled electrical motor (no mechanical brake* that will wear out), counter movement with pack protection
Longitudinal seal:	constant temperature, continual operation, suitable for all heat shrink films listed above, no limit on seal length; option of film draw system (registered design) for films thicker than 8 micron, films with limited shrink ability, or products with a height of more than (6") 150 mm
Infeed conveyor/ outfeed conveyor:	inverter drives, infinitely variable conveyor speeds, option of kiss conveyor between infeed and outfeed conveyor for short products
Control system:	programmable industrial controller, operator panel with colour touch screen that provides a graphical user interface with intuitive user guidance, job storage for 100 job settings. Optional: storage for additional 500 job settings
Sensors:	cable connections of either plugs and sockets or screw terminals, touch free sensing, 'product present' indication
Air requirements:	(85 psi) cfm 6 bar, oil-free
Optional accessories:	fully automatic, motorised machine pre-setting, job setting memory for storing machine, setting under a job number, print registration, label applicator, printing unit, Euro slot punch, further optional accessories on request.

\* depending on product and machine configuration

Note: Technical details are subject to change without notification

## Technical Data – Shrink Tunnel

	SC 40...	SC 60...	SC 80...	SC 100...	SC 120...
Tunnel opening, width	(18") 450 mm	(23½") 600 mm	(31½") 800 mm	(39") 1000 mm	(47") 1200 mm
Tunnel opening, height	(12") 300 mm	(12") 300 mm	(12") 300 mm	(16") 400 mm	(16") 400 mm
Heat chamber, length	(31½" – 110") 800 – 2800 mm	(43" – 165") 1100 – 4200 mm	(59" – 110") 1500 – 2800 mm	(79") 2000 mm	(79") 2000 mm
Heating power	8,4 – 25,2 kW	12,6 – 50,4 kW	16,8 – 37,8 kW	33,6 kW	42 kW

Electrical requirements: 3L, NPE 400 V/50 Hz

Insulation: (4") 100 mm thickness, between heat chamber and outer housing, prevents heat loss

Heat resistant silicon curtains at tunnel entry and exit

Whisper quiet blower motor

Working height: 850 ± 50 mm (33½" ± 2")

Bespoke dimensions on request

### BVM Standard Colours:

RAL 1013 Oyster White

RAL 5007 Brilliant Blue

RAL 6011 Reseda Green

# Possible Configuration

## Coupecta 5022

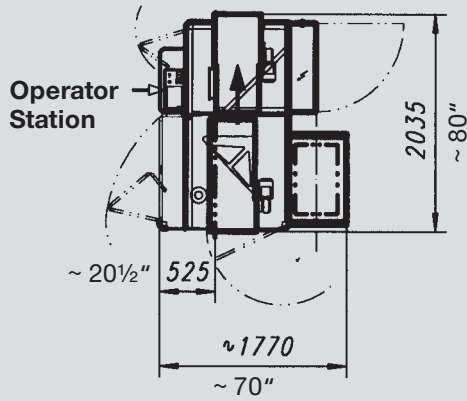

Weight, 770 kg approx.

## Coupecta 7522

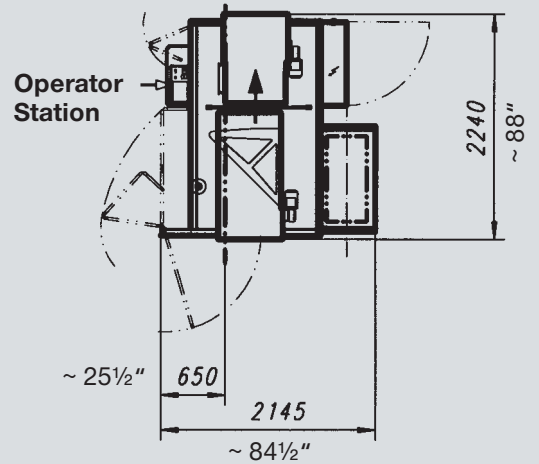

Weight, 780 kg approx.

## Coupecta 10022

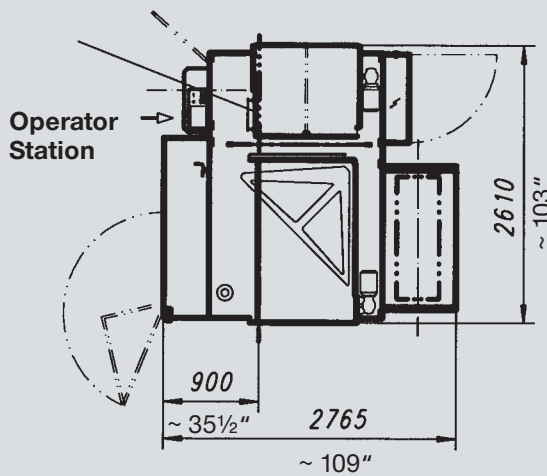

Weight, 800 kg approx.

## Coupecta Kouti 5015 Servo

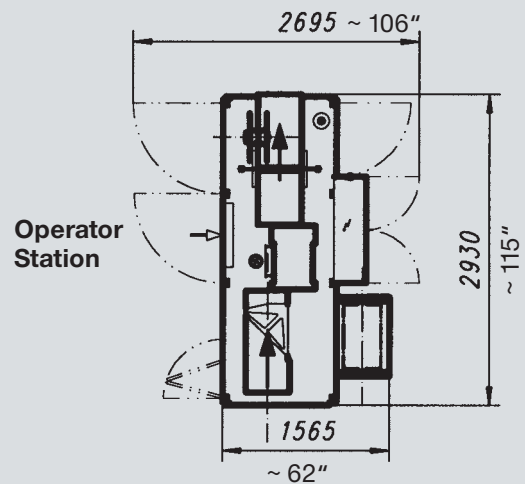

Weight, 1,000 kg approx.

## Shrink Tunnel SC 4030

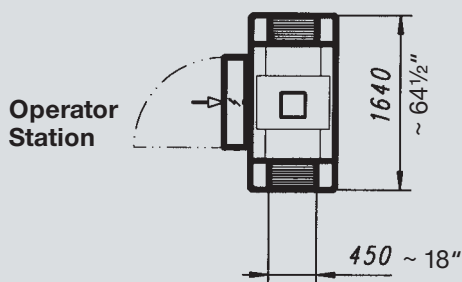

Weight, 400 kg approx.

## Shrink Tunnel SC 4030 SD

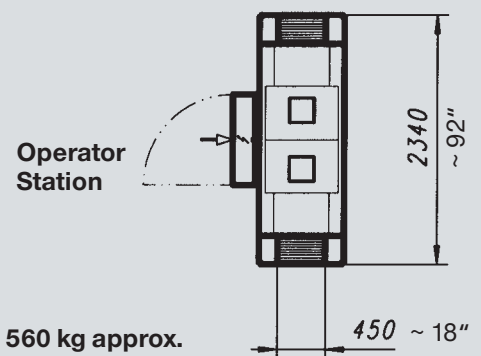

Weight, 560 kg approx.

# Location



**Our sales partner near you:**

**Headquarters:**

# BVM

BRUNNER GMBH u. Co. KG  
Packaging machines

Ferdinand-Lassalle-Straße 62 • D-72770 Reutlingen  
(Betzingen – Industriegebiet West)  
Telefon: (+49) 0 71 21 / 9 16 50 • Telefax (+49) 0 71 21 / 91 65 44  
E-Mail: [info@bvm-brunner.de](mailto:info@bvm-brunner.de)  
Internet: [www.bvm-brunner.de](http://www.bvm-brunner.de)