

STARVIEW PACKAGING MACHINERY INC.

9325 TransCanada Hwy. St-Laurent, Montreal, Canada, H4S 1V3
Telephone : (514) 920-0100 Fax : (514) 920-0092

SDC Series
OPERATOR MANUAL

Safety Instructions	1
Installation Instructions	2
Touch Screen	3
Start-Up	4
Maintenance	5
Electrical	6
Spare Parts	7
Limited Warranty	8

All right are reserved, including those to reproduce this book or parts thereof in any form without permission in writing from Starview Packaging Machinery, Inc.

STARVIEW Packaging Machinery periodically changes the information in this manual. STARVIEW Packaging Machinery reserves the right to change product specifications without notice.

STARVIEW Packaging Machinery, Inc. Shall not be liable for technical or editorial errors or omissions contained herein; nor for incidental or consequential damages resulting from the furnishing, performance, or use of this material.

SAFETY INSTRUCTIONS

- Prior to use of machine, operator should thoroughly read this manual
- All electrical connections should be performed by a qualified technician
- Connect power supply using case grounded services only
- Provide access to all controls on panel for operator maneuvering
- Before attempting any maintenance on machine:
 - Turn main power to the OFF position
 - Disconnect power from power source
 - Disconnect air supply
- Always turn main power to the OFF position when machine is not in use
- Keep hands away from all moving parts

WARNING

- * **Do not tamper with switches and other safety features**
- ** **Pressing the emergency stop button does not cut electrical power source to the machine**
- *** **Loose clothing or accessories should not be worn when operating or working near the machine**

INSTALLATION INSTRUCTIONS

- Unpack machine. Carefully remove straps and attachments
- Place the machine in its proper location. Verify that the machine is level
- Connect main power supply to the machine
- Connect air supply to the filter regulator

WARNING

- * **All electrical works should be performed by a qualified electrician**
- ** **Prior to connecting main power supply to the machine, verify voltage and amperage requirements on the serial number plate**

TOUCH - SCREEN SETTINGS

WARNING

- * **Do not use any objects on Operator Interface as it may cause damage to the display screen**
- ** **Always use clean hands when operating the display screen**

- Turn main power to the On position
- **STARVIEW** will appear on screen
- Touch anywhere on screen to activate main menu

- Main Menu will display the following options:
 - **Manual Mode**
 - **Dimensions**
 - **Run/Stop**
 - **Timers and Speed**
 - **Diagnostic**
 - **Data Bank**
 - **Cycle Counter**
 - **Parts List**

- Select any of these options to proceed

Manual Mode

- Press the **Manual** button to activate the Manual Mode features
- Once in Manual Mode, activate features individually
- To terminate Manual Mode Press the **Auto** button

WARNING

- * **If Emergency Stop is activated, machine will automatically return to Auto mode. Remove Emergency Stop and press the Manual button to return into Manual Mode**
- ** **If covers are opened, machine will automatically return to Auto mode. Close the covers and press the Manual button to return to Manual Mode**

Dimensions

- **To Set-Up The Cutting Dimensions:**
 - Steps are to be entered in order from 1-24. 1 being the first cut
 - Each step contains the quantity to be cut and the length of each piece in inches

Run/Stop

- Features can be individually activated/deactivated by selecting the Run/Stop buttons

WARNING

- * **Features will only function if they have been installed on machine**
- ** **Features must be turned to the Stop position if they have not been installed on machine**
- ** **Features in the Run /Stop menu should only be changed at the end of cycles, when machine is stopped**

Timers

- **Conveyor Belt Speed**
 - Set speed of rotation of the belt from 1 to 8
①→1 – Slowest speed; 8 – Fastest speed
- **Die Cutter Down Delay**
 - Delay time before die cutter is activated
- **Die Cutter Down Stay**
 - Length of time required for die cutter to stay in the down position

Cycle Counter

- **Pre-Set Batch Counter**
 - Enter desired value using the thumbwheel
 - Use the “ + ” or “ – ” to increase or decrease production counter
 - Once desired value has been entered, press the **Counter Reset** button to activate new count
- **Batch Counter**
 - Will display current production run
 - Once **Pre-Set Batch Counter** has been reached, machine will stop
 - Press **Counter Reset** to reset the **Batch Counter**
- **Total Counter**
 - Will continuously accumulate all machine cycles for the life of the machine
 - Modification is not possible

WARNING

- * **Pre-Set Batch Counter will only reset to new value once the Batch Counters Reset button has been applied**

Diagnostic

- Diagnostic page will display all features status
- Highlighted features are activated/detected
- Non-highlighted features are not activated/detected

Data Bank

- Set up the **Timers**
- Go to **Data Bank** page. This page will display all timers as they have been set up
- Once a job has been set up and all timers are correct for a specific job, assign any **Bank** number desired and press **Save**. Repeat this for each new job
- To retrieve a job setting that has already been saved, choose the Bank number using the thumbwheel and press **Read**. Timers will be automatically set up for the desired job

WARNING

- * **Keep record of Bank numbers already used. Do not use same Bank numbers, as this will overwrite previously saved data**
- ** **Heater Control value is for reminder purposes only, as it will not change any of the settings on the temperature control interface. Verify temperature control value and set it up on the temperature control unit located on the front panel**

Parts List

A list of all components

START – UP

WARNING

- * **Keep hands clear from all moving parts**
- ** **Do not tamper with switches and other safety features**
- *** **Pressing the emergency stop button does not cut electrical power source to the machine**
- **** **Loose clothing or accessories should not be worn when operating or working near the machine**
- ***** **Once Pre-Set Batch Counter has been reached, machine will stop. Press the Counters Reset button to reset the batch counter or turn the Pre-Set Batch Counter off to continue**
 - Turn **ON** the main power switch
 - Connect **Air** to the Filter Regulator
 - Air Filter Regulator should be set to **80 PSI**
 - Set up the Timers
 - Set up all features in the Run/Stop menu
 - Set up the cutting dimensions required to be cut in the **Dimensions** menu
 - Set up the Belt Speed
 - Set up the Counter
 - Close all covers
 - Place skin board/products on conveyor belt
 - Press the **Cycle Start** button to start the machine
 - Pass skin package through machine
 - Press the **Cycle Stop** button to stop the machine before the end of the cycle
 - Press the **Emergency Stop** button only for emergencies

Main Controls

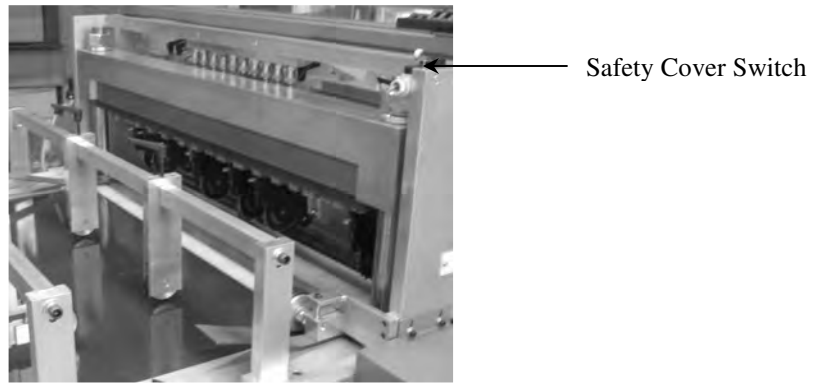

Knives

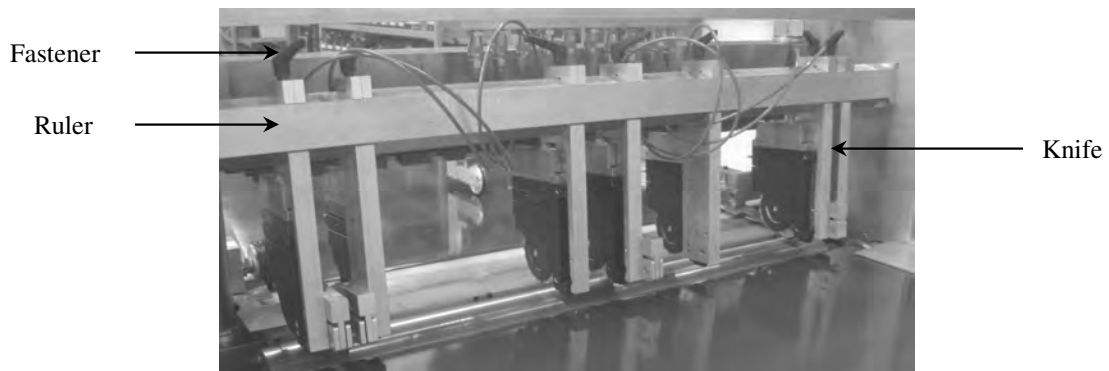

- **To Adjust Knife Spacing:**
 - Loosen **Fastener** and adjust **Knives** as required

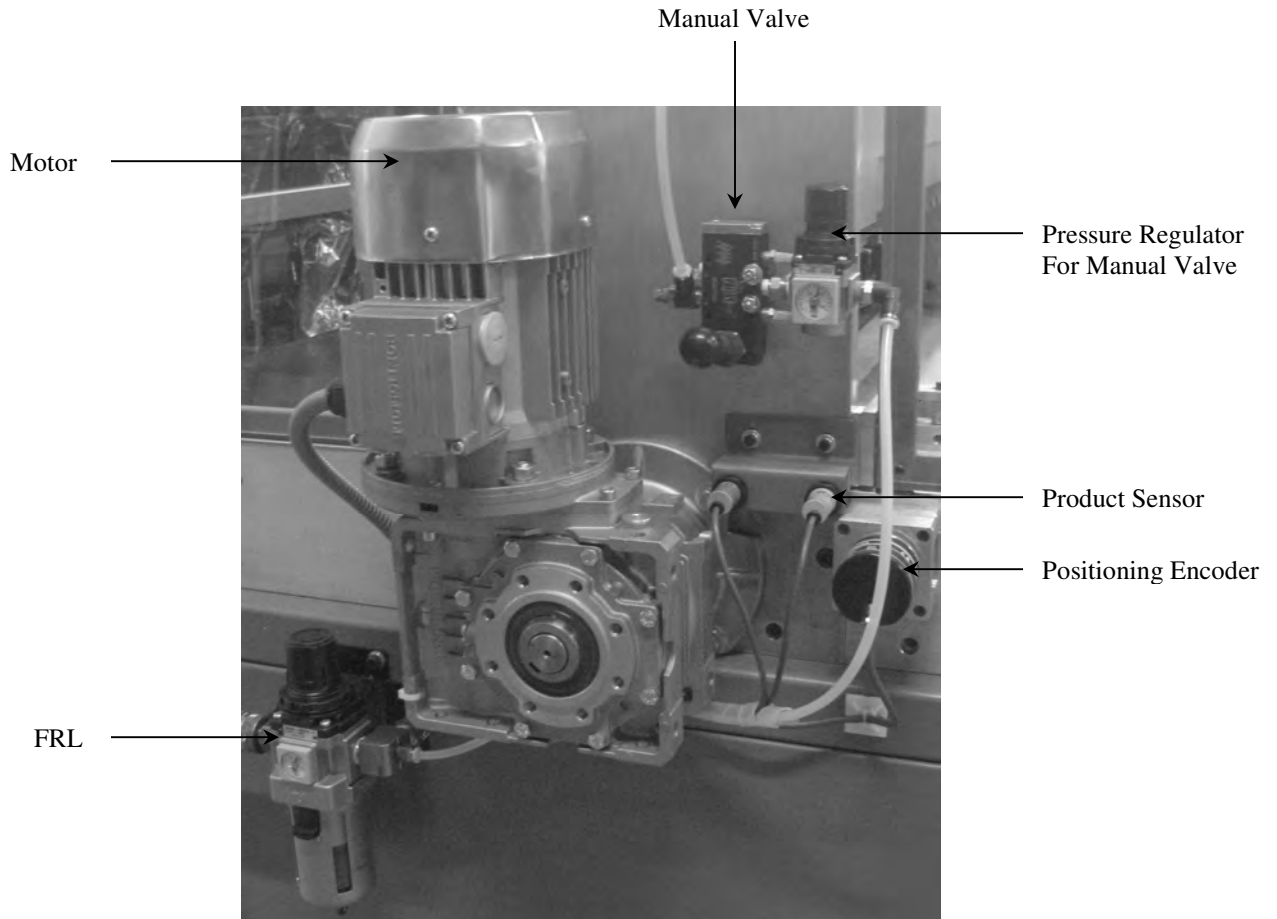

- **To Change Knives:**
 - Use **Manual Valve** to release **Knives**
 - Insert new **Knives** and return **Manual Valve** to original position

Conveyor Belt

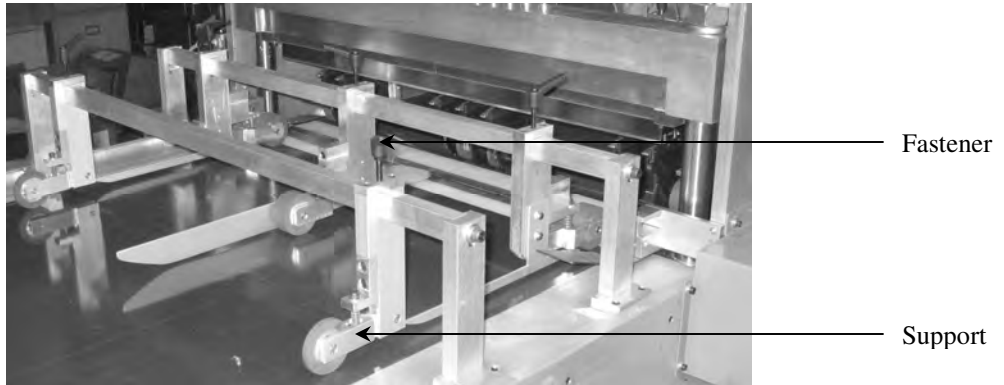

- **To Adjust Supports:**
 - Loosen **Fastener** and adjust **Supports** as required

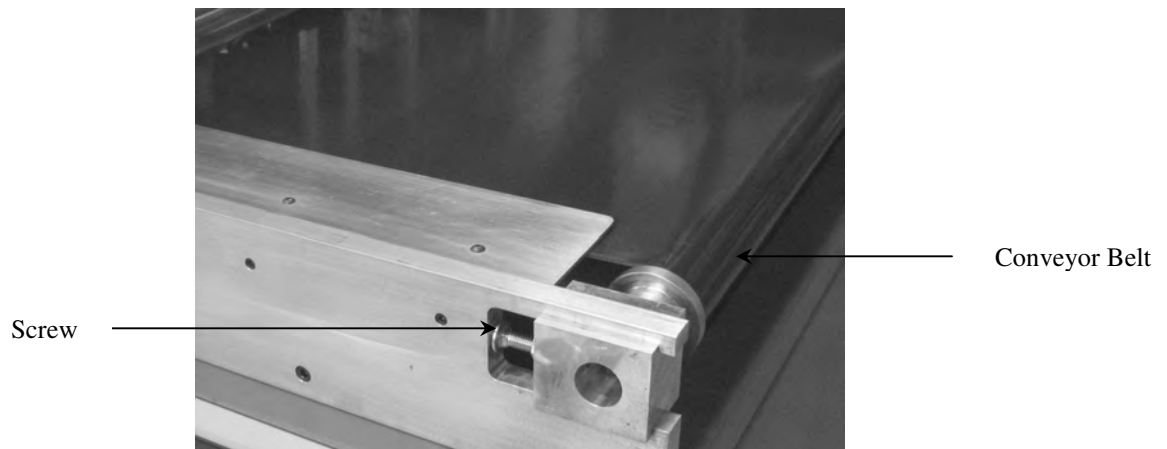

- **To Adjust Conveyor Belt Tension:**
 - Adjust **Screws** on both sides as required to increase/decrease tension

Die Cutter

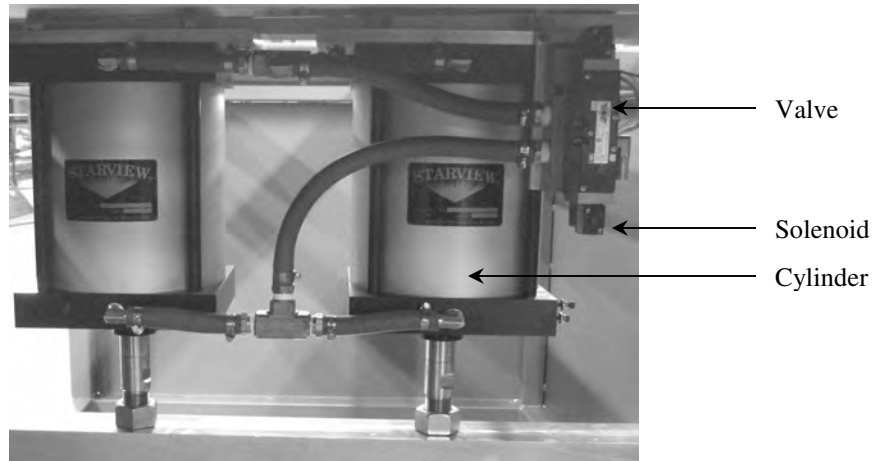

- **To Manually Activate The Die Cutting Cylinder's:**
 - Press the **Solenoid Buttons** on the **Valve** to activate the **Die Cutter**

- **To Change The Cutting Die:**
 - Remove the 4 bolts securing the die in place

Air Filter Regulator

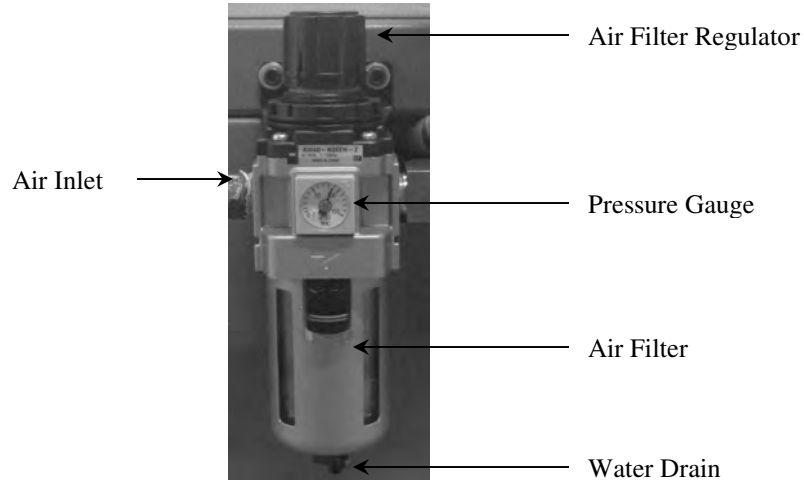

- Connect Air supply to **Air Inlet**
- Air flow to the machine can be controlled through the **Air Filter Regulator**
 - **Air Filter Regulator** should be set to **80 PSI**
 - Turn clockwise to increase air flow
 - Turn counter clockwise to decrease air flow
- Drain the **Air Filter** daily or as needed
 - Press the **Water Drain button** to clean out filter

MAINTENANCE

WARNING

- * **Pressing the emergency stop button does not cut power source to the machine**
- ** **Disconnect air supply to machine before attempting any maintenance**
- *** **Do not touch or get any grease on any electrical components or connections**

- Drain water from the **Air Filter Regulator** Daily or as needed
 - Clean **Filter** and **Lubricator** bowls as necessary
 - Wash bowls using warm water with mild soap
 - Do not clean bowl using solvents as they may weaken the bowls material and cause the bowls to fail when pressurized
- Adjust **Conveyor Belt** tension if required:
 - Adjust **Screws** on both sides as required to increase/decrease tension
- Clean and Grease all sliding and rotating parts every 2 months or 500,000 cycles







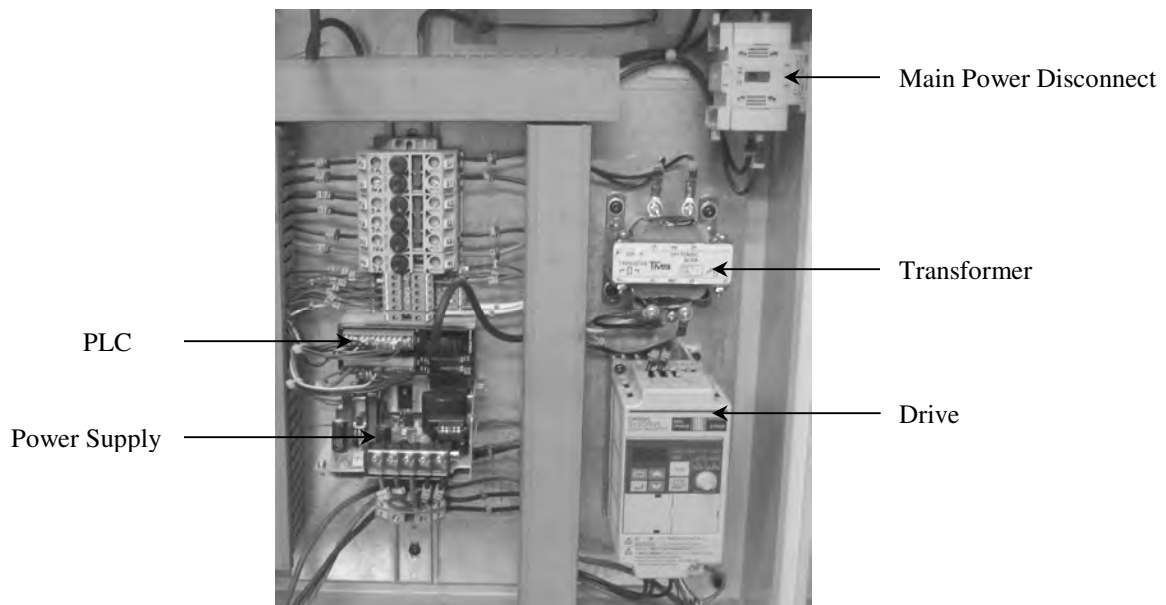



ELECTRICAL

















































































WARNING

- * All electrical works should be performed by a qualified electrician
- ** Prior to connecting main power supply to the machine, verify voltage and amperage requirements on the serial number plate
- *** Do not tamper with the Drive adjustments. They are preset, and should permanently remain at factory settings







PROGRAMMING THE DRIVE CONTROLLER

1. Power up unit
2. Press the **Mode Key**  repeatedly until the **PRGM** indicator is lit.
3. Press  or  for choosing a parameter from **A (n0 i)** to **I (n39)**.
4. Press **Enter Key**  for enters a parameter, the data will be displayed.
5. Press  or  for changing the setting values, the display will flash.
6. Press **Enter Key**  for records the new value and the data display will be lit.
7. Press  or  for choosing the next parameter.
8. For running, return to the **FREF** Monitor with Mode Key 





	Parameter	Description	To Enter	New Setting	To Enter Or To Exit	Next Parameter
A	<i>n01</i>	Initializes parameters in 2-wire sequence		8		 or 
B	<i>n02</i>	Operation Command Selection (Multifunction Inputs)		1		 or 
C	<i>n03</i>	Frequency reference (n21)		1		 or 
D	<i>n05</i>	Reverse Rotation Prohibit		0		 or 
E	<i>n09</i>	Maximum Frequency		60.0		 or 
F	<i>n10</i>	Maximum Voltage		230		 or 
G	<i>n16</i>	Acceleration (sec.)		0.1		 or 
H	<i>n17</i>	Deceleration (sec.)		0.0		 or 
I	<i>n21</i>	Frequency Reference 1		10.00		 or 
J	<i>n22</i>	Frequency Reference 2		15.00		 or 
K	<i>n23</i>	Frequency Reference 3		20.00		 or 
L	<i>n24</i>	Frequency Reference 4		30.00		 or 
M	<i>n25</i>	Frequency Reference 5		40.00		 or 
N	<i>n26</i>	Frequency Reference 6		50.00		 or 
O	<i>n27</i>	Frequency Reference 7		55.00		 or 
P	<i>n28</i>	Frequency Reference 8		60.00		 or 
Q	<i>n36</i>	Multifunction Input 1 - Reverse		2		 or 
R	<i>n37</i>	Multifunction Input 2 – Ref. 1		6		 or 
S	<i>n38</i>	Multifunction Input 3 – Ref. 2		7		 or 
T	<i>n39</i>	Multifunction Input 4 – Ref. 3		8		 or 

EXAMPLE;





To initialize the parameters $n01$ to 8

KEY SEQUENCE	INDICATOR	DISPLAY EXAMPLE	EXPLANATION
	FREF	<i>0.0</i>	Power On
	PRGM	<i>n01</i>	Press the Mode Key repeatedly until the PRGM indicator is lit.
	PRGM	<i>1</i>	Press the Enter Key. The data will be displayed.
	PRGM	<i>8</i>	Use the Increment or Decrement Key to set the new value.
	PRGM	<i>8</i>	Press the Enter Key so that the set value will be entered and the data display will be lit.
In approximately 1 sec.	PRGM	<i>n01</i>	The parameter number will be displayed

To initialize the parameters $n02$ to 1

	PRGM	<i>n02</i>	Use the Increment Key to go to the next parameter
	PRGM	<i>0</i>	Press the Enter Key. The data will be displayed.
	PRGM	<i>1</i>	Use the Increment or Decrement Key to set the new value.
	PRGM	<i>1</i>	Press the Enter Key so that the set value will be entered and the data display will be lit.
In approximately 1 sec.	PRGM	<i>n02</i>	The parameter number will be displayed

To initialize the last parameters $n39$ to 8

	PRGM	<i>n39</i>	Use the Increment Key to go to the next parameter
	PRGM	<i>6</i>	Press the Enter Key. The data will be displayed.
	PRGM	<i>8</i>	Use the Increment or Decrement Key to set the new value.
	PRGM	<i>8</i>	Press the Enter Key so that the set value will be entered and the data display will be lit.
In approximately 1 sec.	PRGM	<i>n39</i>	The parameter number will be displayed
	FREF	<i>60.0</i>	Press the Mode Key repeatedly until the FREF indicator is lit.

SPARE PARTS

ELECTRICAL

Product Name	Serial Number
Screen	NT21-ST121B-E
PLC	CPM2C-20CDR-D
Cable	NT2S-CN224
Drive	3G3JV-AB004-A
Encoder	E6C2-CWZ5B
Coupling	E69-C06B
Main Power Disconnect	LE7-25-1753
Main Power Handle	LFS-N-6-175
Sensor	E3F2-7B4-2M
Power Supply	S82J-02524AD
Proxy Sensor	E2A-M12LS04-WP-B1
Fuse	GDL3
Fuse	GDL10
Fuse Holder	AB1FU10435U
Safety Switch	Z-15GW22-B7-K
Safety Switch Cover	IBDA9000750
Transformer	DO9186SC

PNEUMATIC

Product Name	Serial Number
Cylinder	Code #180
Valve For Cutting Die	93A-EAB-CAA-DM-DJCP-1DG
Valve For Knives	EKCA8/MF
Air Filter Regulator	AW40-N04EH-Z
Regulator	AR20K-N02EH-Z

MECHANICAL

Product Name	Serial Number
Gear Motor	W63UF1100P71B5B3-BN71B4
Belt	NAB8EXDV (CP-3030-04-111)
Belt	NAB8EXDV (CP-3030-04-110)
Knife Holder	45 023-A 000 0
Housing for Knife	45 028-A 000 0
Perforated Blade	21 440 19 25 C
Regular Blade	20 080 50 30 C
Fastener	3T32F33K

LIMITED WARRANTY

STARVIEW provides a Ninety (90) Days warranty on its equipment (without limitations as to number of cycles), if properly installed and used in accordance with instructions. Warranty for components are divided into two categories, as follows;

Components

Components are warranted to be free from defects in materials and workmanship for a period of 1 year from the date of delivery of machine. During this 1 year period, **STARVIEW** will (at its' option) either repair or replace any failed component of its' equipment.

Wear Parts

Parts designed to wear in normal operation and be replaced periodically are warranted to be free from defects for a period of ninety (90) days from date of delivery of machine. Warranty does not extend to parts where damage was caused by normal wear, negligence, accident, abuse, or improper installation or operation.

**** Except as stated herein, STARVIEW makes no other warranty, expressed or implied. This warranty does not apply to equipment which has been, in the judgment of STARVIEW, subjected to misuse, neglect, abuse, and/or repaired or altered by unauthorized personnel. Defective parts must be returned to STARVIEW, freight prepaid, within 14 days of shipment of the replacement part. Defective parts must be returned in their original state. Defective parts that have been disassembled, damaged during removal, or otherwise tampered with, will not be covered under warranty. Unless otherwise stated in writing, STARVIEW makes no other warranty as to suitability of equipment for particular purposes. STARVIEW's sole obligation under this warranty will be to provide repairs, or replacement parts, F.O.B. STARVIEW's point of shipment. ****

**** STARVIEW assumes no responsibility for the quality and performance of films, boards, or any other materials used with its' equipment. ****