

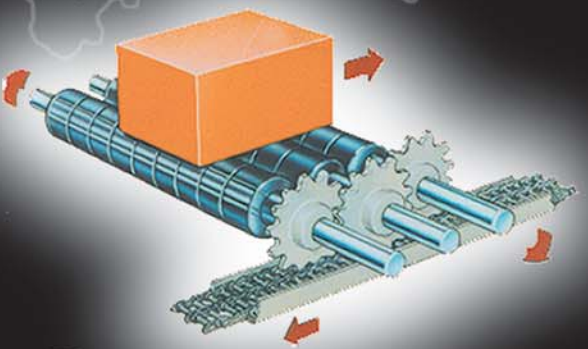

ADVANTAGE SHUTTLEWORTH



Chain Drive

Cleanliness

- Suitable for class 100 (ISO Class 5) clean environments
- 316 SS available for chemical or irradiation applications
- Anti-microbial plastics are designed to inhibit bacteria

Slip-Torque Technology

- Slip-fit rollers minimize product damage
- Low line pressure provides gentle product accumulation
- Close roller shaft centers offer maximum product stability

Innovative Custom-Engineered Solutions

- Modular design allows for future reconfiguration
- Ergonomic operator requirements may be incorporated
- Inherent safety of Slip-Torque design meets OSHA standards

Products Handled

- Catheters
- Contact lens solution
- Contact lens trays
- Cosmetics
- Dental Floss
- Diagnostic Kit
- Eyeglass lens disks
- Gauze
- IV drip bags & bottles
- Joint Implants in baskets
- Medicated patches
- Nutraceutical bottles
- Pharmaceutical blister packs & bottles
- Sanitary diapers and pads
- Surgical Kits
- Syringes, ampoules, test tubes & vials in trays
- Toothpaste
- Wet Wipes – stacked raw, bagged, in tubs or cartons
- X-ray film

Shuttleworth's new formed stainless steel frame design is suitable for most pharmaceutical and medical production environments.

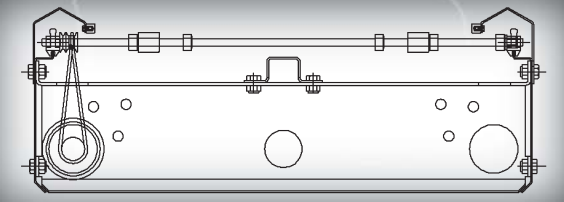

Belt Drive

Available in chain or belt drive design.



Shuttleworth capabilities include electronic data documentation to comply with Good Manufacturing Process (GMP) requirements and the Food and Drug Administration (FDA) Title 21 Code of Federal Regulations (CFR).



Huntington, Indiana, USA



Sint Martens Latem, Belgium

USA: 800.444.7412
Europe: +32.9.221.13 14
Southeast Asia: 603.62767393



World Headquarters
10 Commercial Rd., Huntington, IN 46750 USA
T. 800.444.7412 / 260.356.8500 | Fax: 260.359.7810
inc@shuttleworth.com

Shuttleworth Southeast Asia
PO Box 36, Jinjang,
52000 Kuala Lumpur, Malaysia
T. 603.62767393
sea@shuttleworth.com

Shuttleworth Europe N.V.
Xavier de Cocklaan 86-88
B-9831 Sint Martens Latem (Deurle), Belgium
T. +32.9.221 13 14 | F. +32.9220 28 96
senv@shuttleworth.com

ISO 9001:2000 Certification Shuttleworth, Inc.

Visit us at: www.shuttleworth.com

HEALTHCARE



KITTING APPLICATIONS



Manual Tray Loading

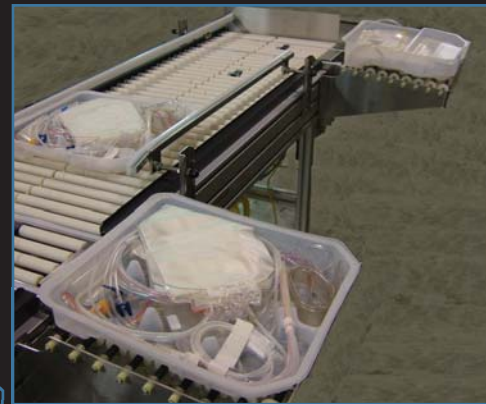

Kit Assembly

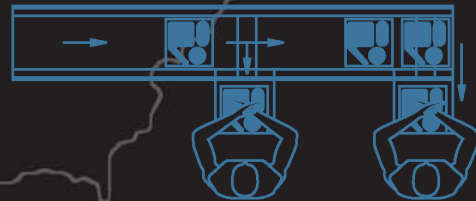

IV BAG APPLICATIONS



Rotating / Centering



Case Packing



Case Packer Infeed



Manual Pack Station



Product Pushing



Single Rowing



Mass Accumulation

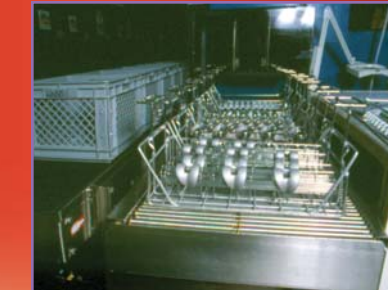

Special Tray Handling



Multi Lane

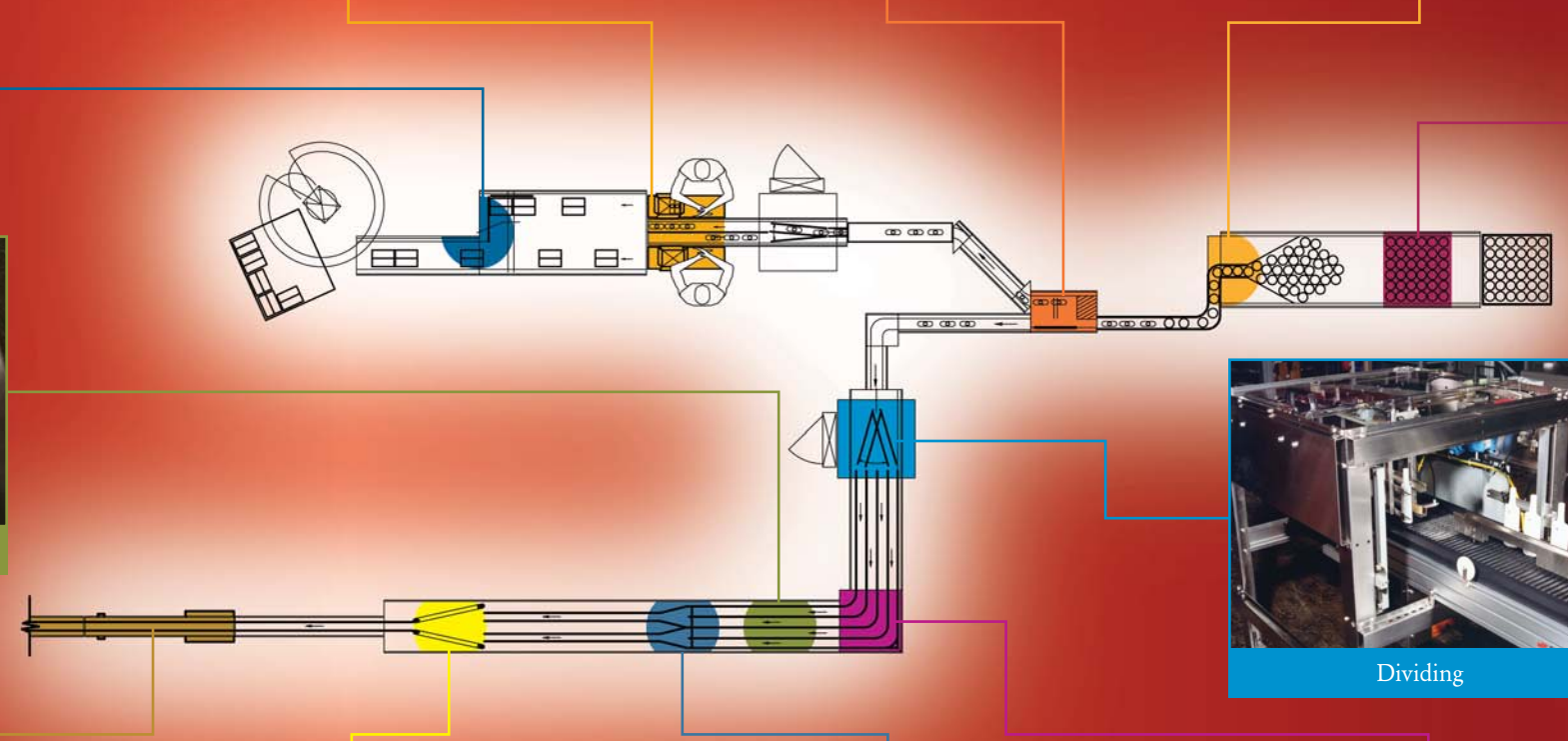

Dividing



Lift Gate



Servo Combining



Gate Combining



Tight Turn Radius

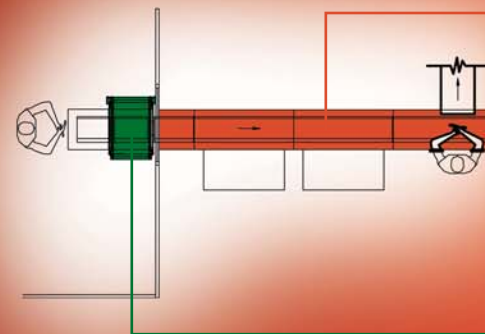

Mini Clean Environment



Clean Pass Through